

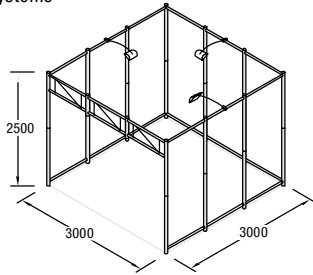



# BASIC MODULES:

## 3x3 systems



**Q 40**  
Construction set including 2 transport cases Q 501, Q 502 and lighting  
weight: 176.37 lb/80.0 kg

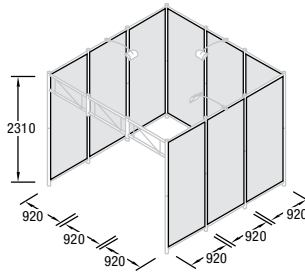

**Q 41**  
Wall infill panel set "fabric", white, with inserted mounting profile  
weight: 23.35 lb/11.5 kg

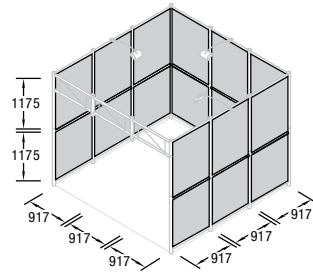

**Q 42**  
Wall infill panel set "wood", white, 3.2 mm, including 9 beams and transport case Q 503  
Suspending the fabric panel  
weight: 178.57 lb/81.0 kg

## 3x2 systems

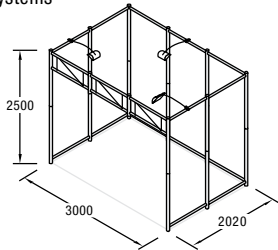

**Q 30**  
Construction set including transport case Q 502 and lighting  
weight: 147.71 lb/67.0 kg

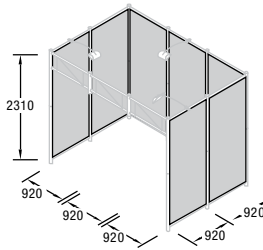

**Q 31**  
Wall infill panel set "fabric", white, with inserted mounting profile  
weight: 19.84 lb/9.0 kg

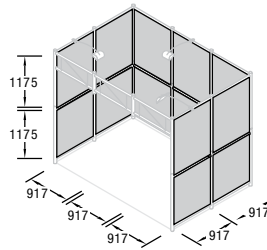

**Q 32**  
Wall infill panel set "wood", white, 3.2 mm, including 7 beams and wooden case  
weight: 119.05 lb/54.0 kg

## 3x1 systems

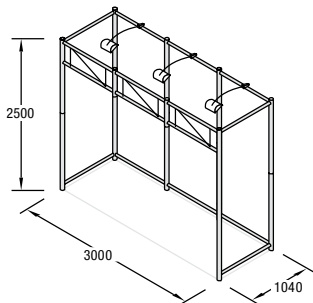

**Q 20**  
Construction set including transport case Q 502 and lighting  
weight: 120.15 lb/54.5 kg

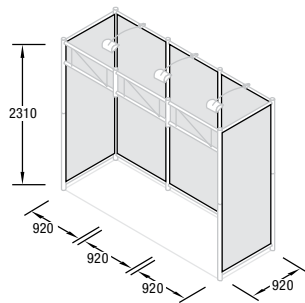

**Q 21**  
Wall infill panel set "fabric", white, with inserted mounting profile  
weight: 11.24 lb/5.1 kg

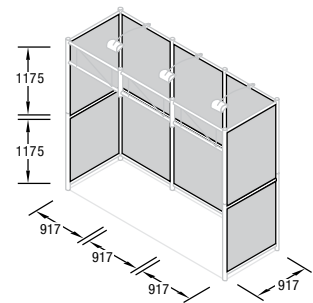

**Q 22**  
Wall infill panel set "wood", white, 3.2 mm, including 5 beams and wooden case  
weight: 85.98 lb/39.0 kg

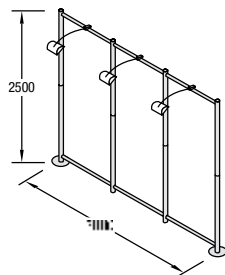

**Q 10**  
Construction set including cardboard box and lighting  
weight: 70.55 lb/32.0 kg

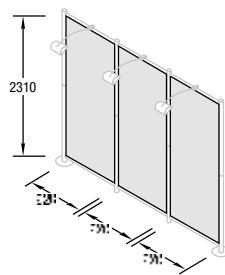

**Q 11**  
Wall infill panel set "fabric", white, with inserted mounting profile  
weight: 8.38 lb/3.8 kg

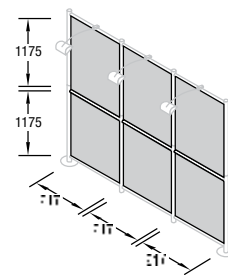

**Q 12**  
Wall infill panel set "wood", white, 3.2 mm, including 3 beams and wooden case  
weight: 52.91 lb/24.0 kg

For extended models, accessories and technical information see page 13